



International Journal of Contemporary Educational Research (IJCER)

www.ijcer.net

The Mediating Role of Task Value in Relationship between Self-Efficacy and Approach Goals Orientations in Science

Pelin Mete¹

¹ Ataturk University

Article History

Received: 26.10.2020

Received in revised form: 04.04.2021

Accepted: 06.05.2021

Available online: 30.06.2021

To cite this article:

Mete, P. (2021). The mediating role of task value in relationship between self-efficacy and approach goals orientations in science. *International Journal of Contemporary Educational Research*, 8(2), 57-67. DOI: <https://doi.org/10.33200/ijcer.817409>

This article may be used for research, teaching, and private study purposes.

Any substantial or systematic reproduction, redistribution, reselling, loan, sub-licensing, systematic supply, or distribution in any form to anyone is expressly forbidden.

Authors alone are responsible for the contents of their articles. The journal owns the copyright of the articles.

The publisher shall not be liable for any loss, actions, claims, proceedings, demand, or costs or damages whatsoever or howsoever caused arising directly or indirectly in connection with or arising out of the use of the research material.

The Mediating Role of Task Value in Relationship between Self-Efficacy and Approach Goals Orientations in Science

Pelin Mete^{1*}

¹ Ataturk University

Abstract

The current study aims to investigate whether there is a meaningful effect of self-efficacy and task value on the achievement approach goals in learning science. In line with this purpose, a correlational method was used in the current study. The participants of this study were 310 middle school students from six public schools (close to each other in terms of socio-economic level and opportunities) in different districts of Erzurum in Turkey. Data were collected through two previously validated instruments: The Achievement Goal Questionnaire and The Motivated Strategies for Learning Questionnaire (self-efficacy and task value subscales). The Achievement Goal Questionnaire was used to determine the students' approach goal orientations (mastery-approach and performance-approach) and The Motivated Strategies for Learning Questionnaire scale was used to assess the students' task value and self-efficacy perceptions. The data obtained were analyzed in two parts. In the first part, SPSS is used for descriptive statistics about variables. The structural Equation Model was used to test the proposed model in the second part. The results of the study have shown that self-efficacy and task value influence the level of students' mastery and performance approach goals. Besides, task value has a partial mediating effect on the relationship between self-efficacy and achievement approach goals. The results of the study were discussed according to the relevant literature.

Keywords: Task Value, Approach Goal Orientations, Self-Efficacy, Mediating Role, Science

Introduction

The issue of motivation, which is one of the factors affecting success in education, has an important place in educational research of recent years (Badiie et al., 2014). The expectation of success and task value, which are among the motivational beliefs, have a significant role in the choice of people's behaviors. While the expectation of success is the students' thoughts about the results of the task before they start it, the reason for doing such a task is defined as the task value (Eccles & Wigfield, 2002; Wigfield & Eccles, 2000). The persistence and effort of the person for any given task depends on his/her self-efficacy and questioning his/her own self and talents. Self-efficacy is an individual's belief in the ability to initiate and execute tasks that will have positive results (Bandura, 1977). Self-efficacy affects individuals' lives in all aspects, including decision-making, persistence on difficult situations, thoughts, behaviors, and emotions (Caraway et al., 2003; Pintrich & Schunk, 2002). Many researchers state that the motivation of the student depends on his / her persistence in performing a task, the energy he/she spends for that task, and his/her desire in the subject matter (Eccles & Wigfield, 2002). In addition, the self-efficacy of students is important in determining the type of goal orientation they have for learning (Liem et al., 2008; You, 2018).

The achievement goal orientations that help determine why people want to achieve something, how they approach achievement and their experiences are divided into two. Researchers first explained goal orientation in two ways: performance goals and mastery goals (Elliot & McGregor, 2001). While the student's focus on understanding, learning, and personal development is their mastery goal orientation, the priority of comparison and performance is the performance goal orientation (Ames, 1992). Students who adopted performance goal orientation avoid difficult tasks, and are vulnerable when unsuccessful. Students who adopted the mastery-approach goal orientation, on the other hand, are willing and persistent in difficult tasks and accept failure not as a personal shortcoming but as an indicator of the need to find new ways to work around such failures. In later

* Corresponding Author: *Pelin Mete*, pelin.mete@atauni.edu.tr

studies, performance-oriented goals were divided into performance approach, and avoidance goals (performance-approach and performance-avoidance), and mastery goals were divided into approach and avoidance (mastery-approach and mastery-avoidance) (Elliot & Thrash, 2001). On the one hand, if individuals use avoidance goals, they aim to avoid negative situations such as failing and making mistakes. The motive for approach examines the working situation for this purpose, considering the positive results. A good example is striving for any success. Avoidance is a motivation to prevent negative consequences that may occur. An example of this is avoiding failure. While mastery-approach in goal orientation focuses on developing skills and knowledge, the performance-based approach is an effort to manifest him/herself, to emphasize abilities, and to appear intelligent (Ames, 1992; Ames & Archer, 1988). In the current study, path analysis was carried out approach goal orientations, which is to improve students' knowledge and skills in a science lesson and to show themselves as competent and hard-working.

The subsequent sections provide an examination of the literature concerning the purpose of task value perception in self-efficacy and achievement approach goals. Research on the relationship among self-efficacy, task value, and achievement approach goals is presented in the coming sections. Based on the conclusions, hypotheses related to these relations were proposed, especially within the area of science.

The Relationship Between Task Value and Self-Efficacy

According to socio-cognitive theory, the perception of self-efficacy affects individuals' lives in many ways, such as their goals, decisions, resolve in the face of difficulties, and the type of tasks they undertake (Bandura, 1993). In summary, self-efficacy explains how individuals behave, think and feel (Caraway et al., 2003). The perception of self-efficacy affects the task value development process of individuals (Wigfield & Eccles, 1992). There is a positive correlation between two motivational beliefs (Eccles & Wigfield, 1995; Meece et al., 1990; Pajares & Miller, 1994). If students have positive beliefs about completing a task, the value for this particular task is high. Higher self-efficacy means higher task value (Cole & Denzine, 2004; Jacobs et al., 2002; Senler & Sungur, 2009). If individuals feel self-sufficient in a given task and believe that they will succeed, they tend to insist on doing the job and work harder (Eccles & Wigfield, 2002; Linnenbrink & Pintrich, 2003; Pajares, 2002) however, if they feel inadequate, they become reluctant and try to avoid the task (Lee, 2009). Based on the literature, self-efficacy and task value have an important and positive relationship, it was hypothesized in this study.

Structural relationship between Achievement Goals and Task Value, Self Efficacy

Task value has a direct correlation with goal orientations. There is a positive relationship between mastery and performance approach goal orientations and task value (Liem et al., 2008; Wolters et al., 1996). If students perceive the assignment as beneficial, interesting and important, they tend to use mastery-approach goal orientations. They develop knowledge and skills by focusing on learning and understanding (Bong, 2004; Hulleman et al., 2008; Xiang et al., 2004) and also try to show their skills to others (Liem et al., 2008).

According to socio-cognitive theory, goal orientations and self-efficacy work in harmony. If the goals are achieved, self-efficacy increases (Caraway et al., 2003). Self-efficacy is the direct cause of goal orientations. Self-efficacy is positively related to performance and mastery-approach goal orientations (Elliot & Church, 1997; Bong, 2001; Liem et al., 2008; Shim & Ryan, 2005). Conversely, some studies in the literature claim a favorable correspondence with self-efficacy and mastery-approach goal orientations (Hsieh et al., 2007; Shim & Ryan, 2005), and no correlation with the performance goal orientations (Philips & Gully, 1997), or a negative correlation between the two (Pajares et al., 2000).

Context of the study

Motivation affects students' learning and performance. At the same time, motivation is affected by the environment and living conditions in which individuals live. The socio-economic level of individuals and their perspective on education are other factors that affect motivation (Sungur & Şenler, 2008). Increasing students' motivation for success is important in achieving the targeted educational goals. Investigating the relationship between self-efficacy, approach goal orientation, and task value help understand students' motivation for success. When the related literature is taken into account, the students' goal orientations and motivational beliefs (task value-self-efficacy) are correlated. In this study, the effects of students' self-efficacy on the approach goal orientation through the mediated impact of the task value were investigated in the science course (Figure 1). Thus, it is aimed to understand the motivation for success of seventh and eighth-grade students in science class. Besides, the relationships between these variables depend on why students perceive a course as significant or want to succeed (Miller & Brickman, 2004). Therefore, it is important to examine these motivational variables in science class. In a limited number of studies, the relationship between self-efficacy, goal orientation, and task

value of Turkish students was examined (Aydın & Yerdelen, 2015; Feyzioğlu, 2019; Kahraman & Sungur, 2013; Pamuk & Elmas, 2015).

The object of the current study is to evaluate the relationships with the structural equation model and to examine the mediating role of task value. The conceptual model created by taking into account the literature was tested using path analysis. The path analysis allows the relationship between variables to be examined at the same time. The model results were compared with the literature and tried to be explained according to the Turkish culture and Turkish education system.

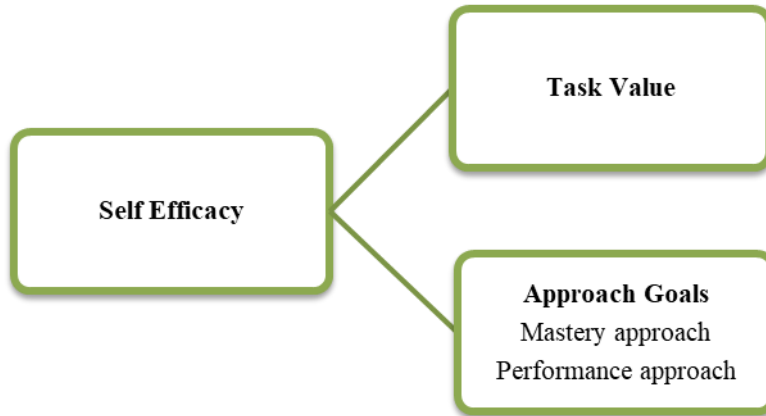

Figure 1. Proposed Model

The proposed model was created as a result of the related literature. Hypotheses created in accordance with the purpose of the research are shown below.

H 1: There is a meaningful and favorable relationship between self-efficacy and mastery approach goals.

H 2: There is a meaningful and favorable relationship between self-efficacy and performance-approach goals.

H 3: There is a meaningful and favorable relationship between self-efficacy and task value.

H 4: The task value has a mediating role in the relationship between self-efficacy and approach goals.

Method

Research Design

The study is a correlational study which examined the relationship between more than two variables without any interference in the environment (Fraenkel & Wallen, 2006). In this study, the relationship between variables (self-efficacy, task value, approach goal orientations) was examined without any interference in the environment.

Sample

The sample in this study included 310 (143 girls, 167 boys) students from six different public schools located in Erzurum. The schools selected for the study are close to each other in terms of socio-economic levels and opportunities they have. In addition, schools are easily accessible for the researcher. The distribution of participants by class level: 149 (48 %) seventh and 161 (52 %) eighth grade student.

Instruments

The Motivated Strategies for Learning Questionnaire (MSLQ)

It was improved by Pintrich et al., (1991), translated and adapted into Turkish by Sungur (2004). A 7-point Likert scale from (1) not at all true of me to (7) very true of me. The self-efficacy subscale consists of 7 items, and the task value subscale consists of 6 items. The task value is defined as the main reason for students to start a task (a sample item: I think I will be able to use what I learn in this course in other courses), while self-efficacy is the student's belief in their own abilities to accomplish a task or learn a subject (a sample item: I'm certain I can master the skills being taught in this class). In the present study, Cronbach alpha coefficients of self-efficacy and task value subscales were 0.86 and 0.75, respectively.

The Achievement Goal Questionnaire

It was developed by Elliot and Church (2001). It consists of 15 items responded on a 5 point Likert scale. The scale including 4 subscales was translated and adapted into Turkish by Senler & Sungur (2007). The four subscales are: mastery-approach (3 items, a sample item: I desire to completely master the material that presented in this class) and performance-approach (3 items, a sample item: It is important to me to do better than other students). While mastery-approach goals focus on self-improvement and willingness to learn new things, performance-approach goals emphasize demonstrating their skills and achievements to others. In the present study, Cronbach alpha coefficients of mastery and performance-approach goals subscales were 0.76.

Prodecure

The study was conducted during regular class hours. Information about the study and how to fill in the questionnaires was provided to students. Students are informed that their answers will remain confidential and will not affect their grades in any way.

Data Analysis

Descriptive statistics (mean, standard deviation, Cronbach alpha coefficients,) related to the variables discussed in the study are carried out through the SPSS 20. The structural equation modelling was performed using AMOS to test the proposed model. The research method proposed by Baron and Kenny (1986) was used to test whether the role of the task value was formed in the structural equation modelling created. This research model consists of three stages:

1. The independent variable affects the dependent variable,
2. The independent variable affects the mediator variable.
3. When the mediator variable is included in the model with the independent variable, the effect of the mediating variable on the dependent variable should be significant, while the effect of the independent variable on the dependent variable is reduced.

Results and Discussion

As a result of the analysis, descriptive statistics (the mean, standard deviation) and bivariate correlation values of the variables were presented in Table 1.

Table 1. Descriptive statistics and bivariate correlation values of the variables

Variables	M	Min-Max	SD	1	2	3	4
1. Self-efficacy	5.34	1-7	1.43	1	0.468**	0.400**	0.285**
2. Task value	5.72	1-7	1.16		1	0.165*	0.442**
3. Mastery approach	4.04	1-5	0.84			1	0.431**
4. Performance approach	4.19	1-5	0.97				1

** Correlation is significant at level 0.01 level (2-tailed),

* Correlation is significant at level 0.05 level (2-tailed)

When the results are examined, it is seen that the arithmetic means of self-efficacy (M = 5.34; SD = 1.43) and task value (M = 5.72; SD = 1.16) are above the mean values of the scales. Moreover, mean values for mastery and performance approach were above the mid-point of the five-point scale. Students tended to have mastery and performance approach at moderate to high levels. It was seen that the highest correlation was between self-efficacy and task value ($r = .468$), the lowest correlation was between task value and mastery approach ($r = .165$).

In order to check the proposed relationships among task value, self-efficacy and approach goals (see Figure 1), structural equation modelling was conducted by using AMOS programme. In the model tested with the help of mediation, it was first tested whether the independent variable (self-efficacy) affects the dependent variable

(mastery and performance-approach goals) (1 and 2 hypotheses). When the model was evaluated , the results indicated evidence to support an adequate model-to-data fit (See Table 2).

Table 2. Structural equation model fit indexes

	χ^2	df	χ^2/df	SRMR	GFI	CFI	RMSEA
Fit Index	122.625	63	1.946	0.061	0.927	0.948	0.063
Good fit indexes			≤ 3	$0 \leq SRMR \leq 0.05$	≥ 0.90	≥ 0.90	≤ 0.05
Acceptable indexes	fit		≤ 5	$0.05 \leq SRMR \leq 0.01$	≥ 0.85		≤ 0.08

$p > .05$ (Şimşek, 2007).

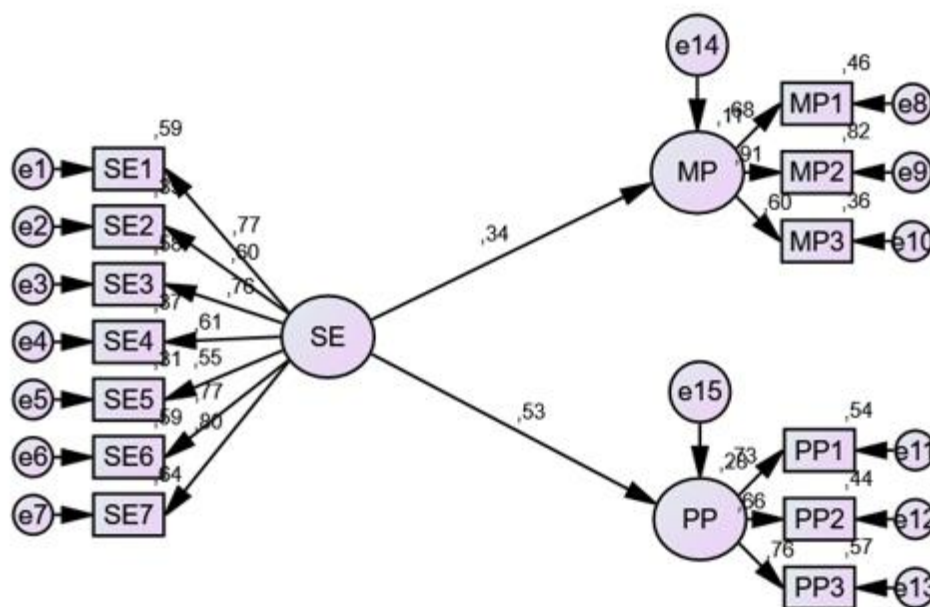

Figure 2. Structural equation model to test predictive effect of self-efficacy on approach goals self-efficacy (se), mastery-approach goals (mp) and performance-approach goals (pp)

Standardized β coefficients, standard error, critical ratio, p and R^2 values among variables according to the generated model are shown in Table 3.

Table 3. Structural equation model coefficients

Variables		Standardize β	Standard Error	Critical Ratio	p	R^2
Self efficacy	Mastery approach	0.34	0.41	4.18	***	0.39
	Performance approach	0.53	0.40	6.26	***	

Results of the analysis showed that self-efficacy predicts mastery approach goal orientations ($\beta=0.34$; $p<0.05$) and performance-approach goal orientations ($\beta=0.53$; $p<0.05$), that is, self-efficacy significantly and positively predicted approach goals. Based on these findings, hypothesis number 1 and 2 of the study is supported. When the squared multiple correlations (R^2) value obtained from the model is investigated, it is determined that self-efficacy explains 39% of the approach goal variance.

The Testing of the Mediating Effect with Structural Equation Model

The mediating role of task value in the relationship between self-efficacy and approach goal orientations was tested through the three-step method proposed by Baron and Kenny (1986). The effects of the independent variable, which is the first stage of the mediation effect, on the dependent variable are revealed (Figure 2). The structural equation modelling for the second and third stages is given in Figure 3.

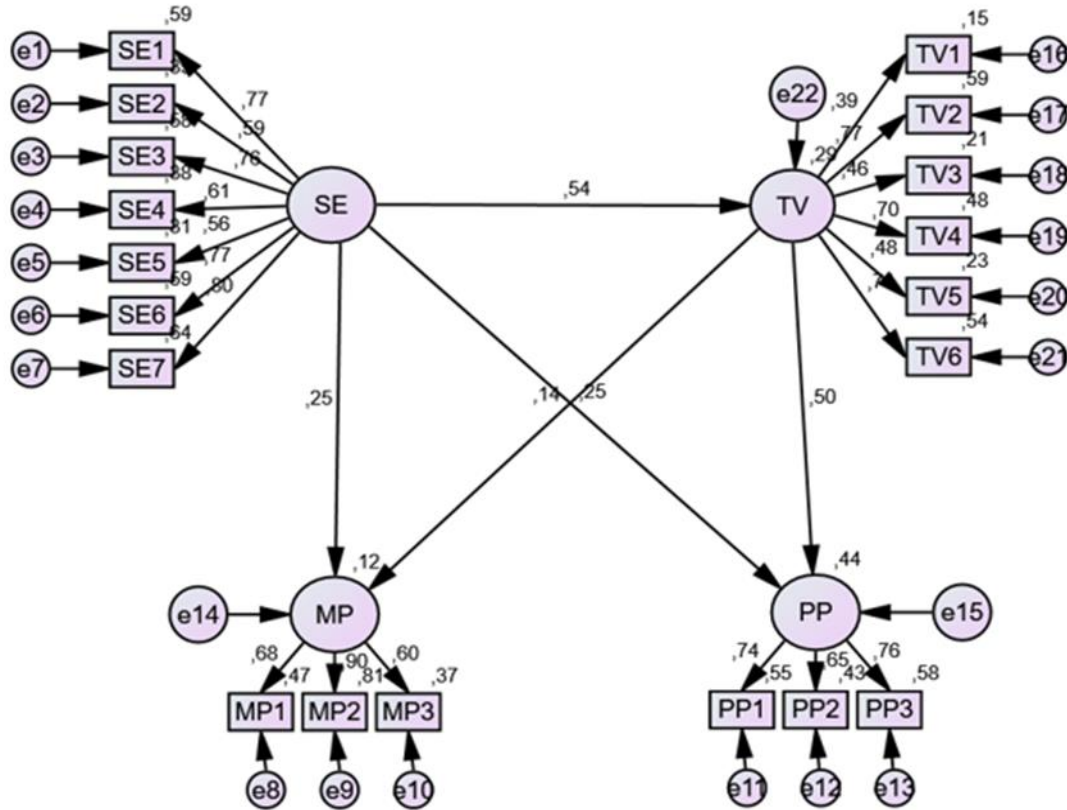

Figure 3. Structural Equation Model to Test Mediating Effect
self-efficacy(SE), mastery-approach goals(MP), performance-approach goals(PP) and task value (TV)

Adaptive values of the model seen in Figure 3 are within acceptable limits, and the model fit values for which the model is structurally appropriate are given in Table 4.

Table 4. Structural equation modeling fit indexes created to measure the mediating effect

	χ^2	df	χ^2/df	SRMR	GFI	CFI	RMSEA
Fit Indexs	254.153	147	1.729	.050	0.901	0.933	0.05
Good Fit Indexs			≤ 3	$0 \leq \text{SRMR} \leq 0.05$	≥ 0.90	≥ 0.90	≤ 0.05
Acceptable Fit Indexs			≤ 5	$0.05 \leq \text{SRMR} \leq 0.10$	≥ 0.85		≤ 0.08

$p > .05$ (Şimşek, 2007)

Standardized β coefficients, standard error, critical ratio, p and R^2 values among variables according to the generated model are shown in Table 5.

Table 5. Structural equation modeling coefficients created to measure the mediating effect

Variables		Standardize β	Standard Error	Critical Ratio	p	R^2
Task value	Self-efficacy	0.54	0.059	4.627	***	0.29
Performance approach	Self-efficacy	0.25	0.042	2.915	0.004	
	Task value	0.50	0.12	4.001	***	
Mastery approach	Self-efficacy	0.25	0.048	2.659	0.008	0.56
	Task value	0.14	0.098	1.444	0.149	

Note: * $p < .05$

If we look at the values in the table 5, it can be seen that there is a statistically significant correlation between self-efficacy and task value ($\beta=0.54$; $p<0.05$). Based on this finding, hypothesis 3 of the study was also supported. When the mediation was included in the model, it was observed that the task value influenced the performance-approach goal orientation ($\beta=0.50$; $p < 0.05$) but did not affect the mastery-approach goal orientation ($\beta=0.14$; $p > 0.05$). However, it was found that the effect of self-efficacy on both mastery-approach and performance-approach goal orientations decreased. Therefore, it can be stated that task value has a mediating role in the relationship between self-efficacy and approach goal orientations. It was observed that the third phase of Baron and Kenny (1986) was partially provided. In light of these findings, the 4th hypothesis of the study is partially supported. If we look at the Squared Multiple Correlations (R^2) value of the model, it can be seen that it explains 56% of approach goal orientations and 29% of the task value.

Conclusion

In the current study, the effects of the self-efficacy of the students in the science course on approach goal orientation were investigated through task value. For this purpose, four different hypotheses were developed and tested. A positive and statistically significant correlation was found between the perception of self-efficacy and mastery and performance-approach goal orientations (Hypothesis 1 and 2). The findings are consistent with the related literature. Elliot and Church (1997) state that students with higher self-efficacy tend to use approach goal orientations. Also, in many studies, a positive correlation was found between self-efficacy and mastery-approach and performance-approach orientations (Bong, 2001; Liem et al., 2008; Shim & Ryan, 2005). This can be explained by the fact that self-efficacy (Bandura, 1993), which is one of the internal factors that need to be activated in order for the individuals to take action, helps individuals to set goals for specific areas, and to seek different solutions to solve the problems they face (Henson, 2001; Pajares, 2002).

The third hypothesis of the study, which is the claim that "There is a statistically significant and positive correlation between self-efficacy and task value", was confirmed. The relevant literature also confirms a positive and statistically significant correlation between the two variables (Eccles & Wigfield, 1995; Feyzioglu, 2019; Meece et al., 1990; Pajares & Miller, 1994; Kahraman & Sungur, 2013; You, 2018). Individuals with high self-efficacy are individuals with high task focus. High task focus enables accurate interpretation of given information and the feedback; the exact opposite occurs in low self-efficacy. In other words, the higher the positive beliefs in completing and accomplishing a task, the more the value given to the task increases (Cole & Denzine, 2004; Eccles & Wigfield, 2002; Jacobs et al., 2002; Senler & Sungur, 2009).

Another finding of the study is related to the last hypothesis formed related to the research (Task value has a mediating role in the relationship between self-efficacy and approach goal orientations). It was found that there was some mediating effect of task value between self-efficacy and approach goal orientations. The partial mediation effect results from the fact that the task value has a statistically significant correlation with the performance approach goal orientation; it has a non-significant correlation with mastery-approach goal orientation. The first part of the fourth hypothesis is that the correlation between task value and performance-approach goals orientations is consistent with the literature. If students find a task interesting and valuable, they tend to show their skills to others while performing this task (Liem et al., 2008; Wolters et al., 1996). The correlation between the task value and mastery-approach goal orientations, which is the second part of the hypothesis, is not supported by the literature. While the relevant literature statistically supports the correlation between the two variables (Bong, 2004; Hulleman et al., 2008; Xiang et al., 2004) the correlation between the

two variables was found to be non-significant in the study. It has also been reported with different results in the literature. For example, in the model development study by Liem et al. (2008), the path between the task value and the goals of approaching performance was removed because there was no relationship. Instead of this path, the path from the task value to mastery goals was added, and a positive relationship was found. The absence of a significant path between task value and mastery approach goals in the present study may be due to the effect of self-efficacy on the performance approach goal. Relationships may be affected by the variance shared with other variables included in the analysis. According to Miller and Brickman (2004), a course becomes important for the realization of goals when students are perceived as beneficial for future goals. Perception of a course from this point of view can result in the development and illustration of ability in the subject, or the consideration of both. In the present study, the positive results of the task value in a science lesson with the performance approach goals may be related to the students showing themselves more capable than their peers. This result can also be explained by the general structure and culture of the Turkish education system. Culture is an important factor in the cognitive, emotional, and motivational development of individuals (Markuset al. 1996 in cited Elliot et al., 2001). Turkey is a country with a traditional and collectivist culture (Caffaro, Ferraris & Schmidt, 2014). In collectivist societies, individuals form themselves based on societal norms (Chiou, 2001; Triandis, 2001). In such societies, individuals tend to behave for the acceptance and appreciation by a community or group rather than emphasizing their individual differences and development. In addition, high levels of fear of failure and social anxiety can be seen in people living in such societies (Eaton & Dembo, 1997). The results obtained can also be explained with the current education system of Turkey. Seventh and eighth graders school students are in a competitive and test-oriented environment. To enroll in a good high school, they need to get a good score at the end of the secondary school test. In such a competitive environment, the student has to prove to his/her surroundings that he/she is smart and that he/she has talents by enrolling in a good high school and getting good grades.

Recommendations

According to these findings, students' opinions about achievement, learning, and considering science lessons important affect each other and differ significantly according to the situations they consider important. For example, is it important to be more successful in science lessons than their peers (performance-approach) or to understand the lesson as well as possible (mastery-approach)? Being highly motivated in a science subject can increase the desire to learn. In the learning environment, task value is an important variable that can affect self-efficacy and approach goal orientations. The study findings show that self-efficacy, task value, and performance approach goal orientations have a remarkable role in the learning and motivation of 7th and 8th-grade Turkish students. Therefore, educators, teachers, and researchers should be aware of the importance of self-efficacy and task value, and goal orientation. In the science education environment, the aim should be to increase students' positive judgments about their science learning capacities. For this reason, teachers may be advised to give students different types of tasks and corrective notifications in science lessons. Students can be allowed to focus on tasks that they do correctly, rather than tasks that they can not do (Pintrich & Schunk, 2002; Linnerbrink & Pintrich, 2003)..

Limitations

There are a few limitations in the study. First, the data of the study were collected through scales. It was assumed that the students answered the questionnaires sincerely. Secondly, this study examined the suggested relationships for science class. Whether the relationships are the same for other areas is not answered in this study. Thirdly, since 7th and 8th-grade Turkish students participated in the study, the results cannot be generalized to all Turkish primary school students. In addition, the data obtained for future studies can be supported by long-term observations and interviews.

References

- Ames, C. (1992). Classrooms: goals, structures, and student motivation. *Journal of Educational Psychology, 84*, 261-271. <https://psycnet.apa.org/doi/10.1037/0022-0663.84.3.261>.
- Ames, C., & Archer, J. (1988). Achievement goals in the classroom: Student's learning strategies and motivation processes. *Journal of Educational Psychology, 80* (3), 260-267. <https://psycnet.apa.org/doi/10.1037/0022-0663.80.3.260>.

- Aydın, S., Yerdelen, S. (2015). An investigation of the relation of high school students' metacognitive strategy use in biology to achievement goal orientation and self-efficacy, *Mersin University Journal of the Faculty of Education*, 11 (3), 781-792. <https://doi.org/10.17860/efd.15845>
- Badiee, H., Babakhani, N., & Hashemian, K. (2014). The Explanation of structural model of academic achievement based on perception of classroom structure and use of motivational strategies in middle schools of Tehran. *Procedia-Social and Behavioral Sciences*, 116, 397-402 <https://doi.org/10.1016/j.sbspro.2014.01.229>.
- Bandura, A. (1993). Perceived self-efficacy in cognitive development and functioning. *Educational Psychologist*, 28(2), 117-148. https://doi.org/10.1207/s15326985ep2802_3.
- Bandura, A. (1977). Self-efficacy: Toward a unifying theory of behavioral change. *Psychological Review*, 84, 191-215. <https://psycnet.apa.org/doi/10.1037/0033-295X.84.2.191>.
- Baron, R. M., & Kenny, D. A. (1986). The moderator–mediator variable distinction in social psychological research: Conceptual, strategic, and statistical considerations. *Journal of Personality and Social Psychology*, 51(6), 1173.
- Bong, M. (2001). Between-and within-domain relations of academic motivation among middle and high school students: self-efficacy, task-value, and achievement goals. *Journal of Educational Psychology*, 93(1), 23-34 <https://psycnet.apa.org/doi/10.1037/0022-0663.93.1.23>.
- Bong, M. (2004). Academic motivation in self-efficacy, task value, achievement goal orientations, and attributional beliefs. *The Journal of Educational Research*, 97(6), 287-297. <https://doi.org/10.3200/JOER.97.6.287-298>.
- Caffaro, F., Ferraris, F., & Schmidt, S. (2014). Gender differences in the perception of honour killing in individualist versus collectivistic cultures: Comparison between Italy and Turkey. *Sex Roles*, 71(9-10), 296-318. doi: 10.1007/s1119.
- Caraway, K., Tucker, C.M., Reinke, W.M., & Hall, C. (2003). Self-efficacy, goal orientation, and fear of failure as predictors of school engagement in high school students. *Psychology in the Schools*, 40(4), 417-427. <https://doi.org/10.1002/pits.10092>.
- Chiou, J. (2001). Horizontal and vertical individualism and collectivism among college students in the United States, Taiwan, and Argentina. *The Journal of Social Psychology*, 141(5), 667-678. <https://doi.org/10.1080/00224540109600580>
- Cole, J.S., Denzine, & G.M. (2004). I'm not doing as well in this class as I'd like to: Exploring achievement motivation and personality. *Journal of College Reading and Learning*, 34(2), 29-44. <https://doi.org/10.1080/10790195.2004.10850160>.
- Eaton, M., & Dembo, M. (1997). Differences in the motivational beliefs of Asian American and non-Asian students. *Journal of Educational Psychology*, 89, 433–440.
- Eccles, J.S. & Wigfield A. (1995). In the mind of the actor: the structure of adolescents' achievement task values and expectancy-related beliefs. *Personality and Social Psychology Bulletin*, 21(3), 215-225. <https://doi.org/10.1177/0146167295213003>.
- Eccles, J. S., & Wigfield, A. (2002). Motivational beliefs, values, and goals. *Annual review of psychology*, 53(1), 109-132. <https://doi.org/10.1146/annurev.psych.53.100901.135153>.
- Elliot, A.J. & Church, M.A. (1997). A hierarchical model of approach and avoidance achievement motivation. *Journal of Personality and Social Psychology*, 72, 218-232. <http://citeseerx.ist.psu.edu/viewdoc/download?doi=10.1.1.431.7950&rep=rep1&type=pdf>.
- Elliot, A., J., & McGregor, H., A. (2001). A 2*2 Achievement goal framework. *Journal of Personality and Social Psychology*, 80, 50-519. doi:10.1037//022-3514.80.3.501 <https://academic.udayton.edu/JackBauer/Readings%20361/Elliot%2001%20ach%20goal%20x2.pdf>.
- Elliot, A. J., Chirkov, V. I., Kim, Y., & Sheldon, K. M. (2001). A cross-cultural analysis of avoidance (relative to approach) personal goals. *Psychological Science*, 12(6), 505-510. <https://doi.org/10.1111/0956-7976.00393>.
- Feyzioğlu, B. (2019) The role of inquiry-based self-efficacy, achievement goal orientation, and learning strategies on secondary-school students' inquiry skills, *Research in Science & Technological Education*, 37(3), 366-392. <https://doi.org/10.1080/02635143.2019.1579187>

- Fraenkel, J. R., & Wallen, N. E. (2006). *How to Design and Evaluate Research in Education*. McGrawhill, Inc.
- Henson, R. K. (2001). The effects of participation in teacher research on teacher efficacy. *Teaching and Teacher Education* 17, 819–836. [https://doi.org/10.1016/S0742-051X\(01\)00033-6](https://doi.org/10.1016/S0742-051X(01)00033-6).
- Hsieh, P., Sullivan, J.R.& Guerra, N.S. (2007). A closer look at college students : Self efficacy and goal orientation. *Journal of Advanced Academia*, 18, 454-476. <https://doi.org/10.4219%2Fjaa-2007-500>.
- Hulleman, C. S., Durik, A. M., Schweigert, S. A., & Harackiewicz, J. M. (2008). Task values, achievement goals, and interest: An integrative analysis. *Journal of Educational Psychology*, 100, 398-416. <https://psycnet.apa.org/doi/10.1037/0022-0663.100.2.398>.
- Jacobs, J.E., Lanza, S., Osgood, D.W., Eccles, J.S., & Wigfield, A. (2002). Changes in children's self-competence and values: gender and domain differences across grades one through twelve. *Child Development*, 73(2), 509-527. <https://doi.org/10.1111/1467-8624.00421>.
- Kahraman, N., & Sungur, S. (2013). Antecedents and Consequences of Middle School Students' Achievement Goals in Science. *Asia-Pacific Education Research*, 22(1), 45-60. <https://doi.org/10.1007/s40299-012-0024-2>
- Lee, J. A. (2009). *Teachers' sense of efficacy in teaching English, perceived English language proficiency, and attitudes toward the English language: A case of Korean public elementary school teachers*. Unpublished doctorate thesis. Ohio State University Department of Philosophy.
- Liem, A., D., Lau, S., & Nie, Y. (2008). The role of self-efficacy, task value, and achievement goals in predicting learning strategies, task disengagement, peer relationship, and achievement outcome. *Contemporary Educational Psychology*, 33, 486–512. <https://doi.org/10.1016/j.cedpsych.2007.08.001>.
- Linnenbrink, E.A. & Pintrich P.R. (2003). The role of self-efficacy beliefs in student engagement and learning in the classroom. *Reading & Writing Quarterly*, 19, 119-137. <https://doi.org/10.1080/10573560308223>.
- Meece, J.L., Wigfield, A., & Eccles, J.S. (1990). Predictors of math anxiety and its influence on young adolescents' course enrollment intentions and performance in mathematics. *Journal of Educational Psychology*, 82(1), 60-70. <https://psycnet.apa.org/doi/10.1037/0022-0663.82.1.60>.
- Miller, R.B., & Brickman, S.A. . (2004). A model of future oriented motivation and self-regulation. *Educational Psychology Review*, 16, 9-33. Retrieved from <https://link.springer.com/article/10.1023/B:EDPR.0000012343.96370.39>
- Pajares, F., & Miller, M. D. (1994). Role of self-efficacy and self-concept beliefs in mathematical problem solving: A path analysis. *Journal of Educational Psychology*, 86(2), 193. <https://psycnet.apa.org/doi/10.1037/0022-0663.86.2.193>.
- Pajares, F., Britner, S. L., & Valiante, G. (2000). Relation between achievement goals and self-beliefs of middle school students in writing and science. *Contemporary Educational Psychology*, 25(4), 406-422. <https://doi.org/10.1006/ceps.1999.1027>.
- Pajares, F. (2002). Gender and perceived self-efficacy in self-regulated learning. *Theory into Practice*, 41(2), 116-125. https://doi.org/10.1207/s15430421tip4102_8.
- Pamuk, S., & Elmas, R. (2015). Prediction of Metacognitive Self-Regulation with Self-Efficacy and Achievement Goals: Example on Afyon Province. *Amasya Education Journal*, 4(2), 175-189.
- Philips, J.M., & Gully, S.M. (1997). Role of goal orientation, ability, need for achievement, and locus of control in the self-efficacy and goal-setting process. *Journal of Applied Psychology*, 82(5), 792-802. <https://psycnet.apa.org/doi/10.1037/0021-9010.82.5.792>.
- Pintrich, P.,R.& Schunk, D., H. (2002). *Motivation in education: theory, research and applications*. Merrill Prentice Hall.
- Senler, B., & Sungur, S. (2009). Parental influences on students' self-concept, task value beliefs, and achievement in science. *The Spanish Journal of Psychology*, 12(1), 106-117. <https://doi.org/10.1017/S1138741600001529>.
- Sungur, S. & Senler, B. (2008). An analysis of Turkish high school students' metacognition and motivation. *Educational Research and Evaluation*, 15(1), 45-62. <https://doi.org/10.1080/13803610802591667>

- Shim, S., & Ryan, A. (2005). Changes in self efficacy, challenge avoidance, and intrinsic value in response to grades: The role of achievement goals. *The Journal of Experimental Education*, 73(4), 333-349. <https://doi.org/10.3200/JEXE.73.4.333-349>.
- Şimşek, Ö.,F. (2007). *Yapısal eşitlik modellemesine giriş: Temel ilkeler ve Lisrel Uygulamaları*. Ankara: Ekinoks.
- Triandis, H. C. (2001). Individualism-collectivism and personality. *Journal of Personality*, 69(6), 907-924. <https://doi.org/10.1111/1467-6494.696169>
- Wigfield, A., & Eccles, J. S. (1992). The development of achievement task values: A theoretical analysis. *Developmental review*, 12(3), 265-310. [https://doi.org/10.1016/0273-2297\(92\)90011-P](https://doi.org/10.1016/0273-2297(92)90011-P).
- Wigfield, A., & Eccles, J. S. (2000). Expectancy–value theory of achievement motivation. *Contemporary Educational Psychology*, 25(1), 68-81. <https://doi.org/10.1006/ceps.1999.1015>.
- Wolters, C. A., Yu, S. L., & Pintrich, P. R. (1996). The relation between goal orientation and students' motivational beliefs and self-regulated learning. *Learning and Individual Differences*, 8, 211–238. [https://doi.org/10.1016/S1041-6080\(96\)90015-1](https://doi.org/10.1016/S1041-6080(96)90015-1).
- Xiang, P., McBride, R., & Bruene, A. (2004). Fourth graders' motivation in an elementary physical education running program. *The Elementary School Journal*, 104, 253–266. <https://doi.org/10.1086/499752>.
- You, J. W. (2018). Testing the three-way interaction effect of academic stress, academic self-efficacy, and task value on persistence in learning among Korean college students. *Higher Education*, 76(5), 921-935. <https://doi.org/10.1007/s10734-018-0255-0>